

# Conformational Preferences of Spirocyclic Pentaoxyphosphoranes Varying in Ring Size<sup>1,2</sup>

K. C. Kumara Swamy, Roberta O. Day, Joan M. Holmes, and Robert R. Holmes\*

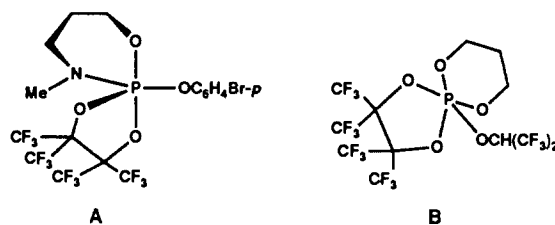
Contribution from the Department of Chemistry, University of Massachusetts, Amherst, Massachusetts 01003. Received November 6, 1989

**Abstract:** New bicyclic pentaoxyphosphoranes 1-3 containing ring sizes varying from five to seven membered were synthesized by oxidative addition of a quinone or a diol to a cyclic phosphite. Variable-temperature solution <sup>1</sup>H and <sup>13</sup>C NMR studies revealed the presence of dynamic intramolecular ligand exchange processes, one in which apical-equatorial ring interchange occurred between trigonal bipyramidal ground states and a higher temperature process supporting an exchange intermediate with the ring located diequatorially in a trigonal bipyramid. Activation energies for the latter process were determined. X-ray analysis supported the interpretation of the solution-state behavior and showed that saturated six-membered rings prefer a boat conformation occupying apical-equatorial positions in trigonal bipyramidal structures. The stability of the six-membered ring in this conformation is supported by the shorter P-O bond lengths found for this ring size compared to that for phosphoranes having five- and seven-membered rings. Phosphorane 1 crystallizes in the monoclinic space group *P*<sub>2</sub><sub>1</sub>/*n* with *a* = 10.633 (3), *b* = 17.648 (3), *c* = 13.601 (1) Å, β = 102.47 (1)°, and *Z* = 4. The bicyclic 2 crystallizes in the monoclinic space group *P*<sub>2</sub><sub>1</sub>/*n* with *a* = 10.459 (2), *b* = 12.712 (1), *c* = 19.949 (2) Å, β = 95.28 (1)°, and *Z* = 4. Bicyclic 3 crystallizes in the monoclinic space group *P*<sub>2</sub><sub>1</sub>/*n* with *a* = 9.655 (4), *b* = 11.662 (4), *c* = 22.720 (6) Å, β = 94.28 (3)°, and *Z* = 4. The bicyclic phosphorane 4 crystallizes in the orthorhombic space group *Pbcn* with *a* = 13.922 (4), *b* = 11.050 (2), *c* = 11.020 (3) Å, and *Z* = 4. The final conventional unweighted residuals are 0.037 (1), 0.093 (2), 0.050 (3), and 0.062 (4).

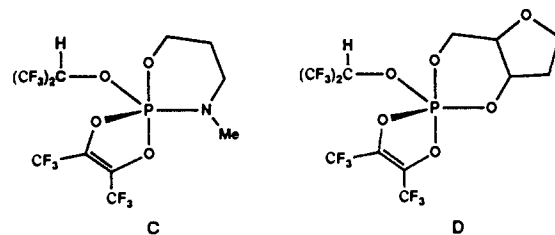
## Introduction

While a great deal of effort has been expended in learning conformational requirements of five-membered rings in oxyphosphoranes,<sup>3,4</sup> little is known about larger ring systems.<sup>16,5</sup> Much of the work on oxyphosphoranes with five-membered rings derives from their interest as intermediates or transition states in non-enzymatic and enzymatic processes,<sup>6</sup> e.g., phosphate ester hydrolysis, an area that has been extensively studied by Westheimer<sup>7</sup> and Ramirez<sup>8</sup> and their co-workers. Similar interests exist for phosphorus compounds with six-membered rings<sup>9-11</sup> particularly with respect to the formation of pentacoordinated intermediates in enzymatic reactions of nucleoside 3',5'-monophosphates such as cAMP.<sup>12-14</sup> Prior structural studies of phosphoranes containing six-membered rings are few but include a ring containing oxygen and nitrogen bonded to phosphorus, A,<sup>15</sup> and one that is a pentaoxyphosphorane, B.<sup>16</sup> Both derivatives

have these rings in a boat conformation. Solution NMR studies



support these findings. Detailed <sup>1</sup>H NMR studies by Yu and Bentrude have indicated the presence of the phosphorinane ring in a nonchair (boat and/or twist) conformation for C<sup>17a</sup> and a twist conformation for D.<sup>17b</sup> Further, they suggest<sup>17b</sup> that the normal conformation for dioxo- and oxazaphosphorinanes is a nonchair form located in apical-equatorial sites.

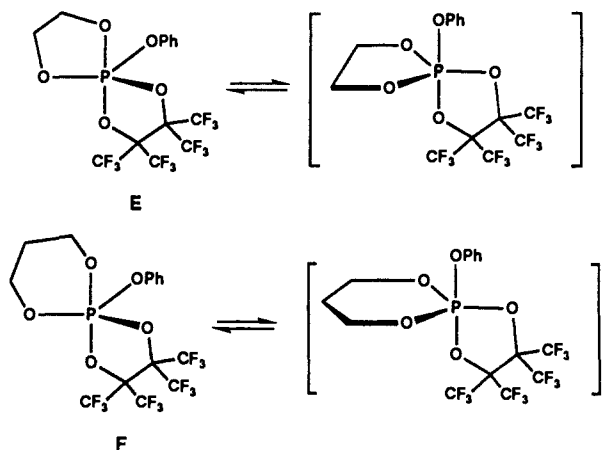


Six-membered rings in trigonal-bipyramidal arrangements are expected to exert less ring strain than five-membered rings.<sup>18</sup> Whereas five-membered rings invariably span apical-equatorial sites, six-membered rings might be expected to be located either apically-equatorially or diequatorially with little energy preference between them. On comparison of ligand exchange energies determined from dynamic NMR studies on cyclic oxyphosphoranes where diequatorial exchange activated states are proposed, it is apparent that six-membered rings provide lower barriers than five-membered ring systems.<sup>18a,19</sup> For example, the pseudotortional process postulated for equilibration of CF<sub>3</sub> groups in E is accompanied by an exchange barrier of 17.4 kcal/mol compared

- (1) (a) Pentacoordinated Molecules. 81. (b) Part 80: Kumara Swamy, K. C.; Holmes, J. M.; Day, R. O.; Holmes, R. R. *J. Am. Chem. Soc.* **1990**, *112*, first of three papers in this issue.  
 (2) Kumara Swamy, K. C.; Burton, S. D.; Holmes, J. M.; Day, R. O.; Holmes, R. R. Presented in part at the XI International Conference on Phosphorus Chemistry, Tallinn, Estonia, SSR/USSR, July 1989; Abstract 2-22.  
 (3) Holmes, R. R. *Pentacoordinated Phosphorus—Structure and Spectroscopy*; ACS Monograph 175; American Chemical Society: Washington, DC, 1980; Vol. 1 and references cited therein.  
 (4) Holmes, R. R. *Prog. Inorg. Chem.* **1984**, *32*, Chapter 2 and references cited therein.  
 (5) Burton, S. D.; Kumara Swamy, K. C.; Holmes, J. M.; Day, R. O.; Holmes, R. R. *J. Am. Chem. Soc.*, following paper in this issue and references cited therein.  
 (6) Holmes, R. R. *Pentacoordinated Phosphorus—Reaction Mechanisms*; ACS Monograph 176; American Chemical Society: Washington, DC, 1980; Vol. II, Chapter 2 and references cited therein.  
 (7) Westheimer, F. H. *Acc. Chem. Res.* **1968**, *1*, 70. *Ibid. Pure Appl. Chem.* **1977**, *49*, 1059.  
 (8) (a) Ramirez, F.; Ugi, I. *Bull. Soc. Chim. Fr.* **1974**, 453. (b) Ramirez, F.; Marecek, J. F.; Ugi, I.; Lemmen, P.; Marquarding, D. *Phosphorus* **1975**, 5, 73. (c) Marquarding, D.; Ramirez, F.; Ugi, I.; Gillespie, P. *Angew. Chem.* **1973**, *85*, 99.  
 (9) Cherkasov, R. A.; Ovchinnikov, V. V.; Pudovik, M. A.; Pudovik, A. N. *Russ. Chem. Revs.* **1982**, *51*, 746.  
 (10) Hall, C. R.; Inch, T. D. *Tetrahedron* **1980**, *36*, 2059.  
 (11) Reference 6, pp 149-163.  
 (12) Van Ool, P. J. J. M.; Buck, H. M. *Eur. J. Biochem.* **1982**, *121*, 329 and references cited therein.  
 (13) Nelson, K. A.; Bentrude, W. G.; Setzer, W. N.; Hutchinson, J. P. *J. Am. Chem. Soc.* **1987**, *109*, 4058.  
 (14) DeWit, J. W.; Hekstra, D.; Jastorff, B.; Stec, W. J.; Baraniak, J.; Van Driel, R. *Eur. J. Biochem.* **1984**, *142*, 255.  
 (15) Barlow, J. H.; Bone, S. A.; Russell, D. R.; Trippett, S.; Whittle, P. *J. J. Chem. Soc., Chem. Comm.* **1976**, 1031.

- (16) Schomburg, D.; Hacklin, H.; Röschenthaler, G.-V. *Phosphorus Sulfur* **1988**, *35*, 241.  
 (17) (a) Yu, J. H.; Bentrude, W. G. *J. Am. Chem. Soc.* **1988**, *110*, 7897. (b) *Ibid. Tetrahedron Lett.* **1989**, *30*, 2195.  
 (18) (a) Trippett, S. *Pure Appl. Chem.* **1974**, *40*, 595. (b) Bone, S. A.; Trippett, S.; Whittle, P. *J. J. Chem. Soc., Perkin I* **1977**, 80.  
 (19) Chang, B. C.; Conrad, W. E.; Denney, D. B.; Denney, D. Z.; Edelman, R.; Powell, R. L.; White, D. W. *J. Am. Chem. Soc.* **1971**, *93*, 4004.

to only 6.1 kcal/mol for F.<sup>18a</sup> Denney and co-workers<sup>19</sup> have

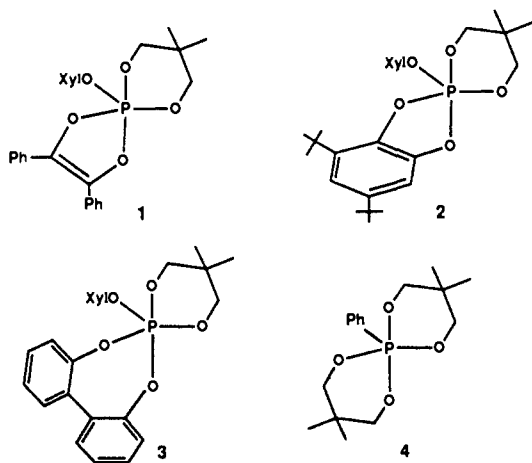


conducted NMR studies on related systems with similar results. Under the postulation of a diequatorial-positioned ring representing the barrier state, the closeness in energy between apical-equatorial and diequatorial placement of six-membered rings implied by these studies suggests that interpretations of nucleophilic displacements at phosphorus containing such rings<sup>10,11,20,21</sup> proceeding by way of pentacoordinated states is subject to greater variability compared to that for phosphorus compounds containing five-membered rings.<sup>6-8</sup>

No structural studies of phosphoranes possessing ring sizes greater than six appear to exist, although Denney and co-workers<sup>22</sup> concluded that seven- and eight-membered rings of monocyclic pentaoxyphosphoranes containing  $\text{OCH}_2\text{CF}_3$  groups are situated in diequatorial positions of a trigonal bipyramid on the basis of an NMR study.

We have initiated a program with the purpose of examining ring systems varying in size that are part of five-coordinated phosphorus molecules with a view toward defining the factors controlling ring conformational requirements. As a consequence, interpretations of nucleophilic displacement reactions at cyclic four-coordinated phosphorus compounds should be placed on a more firm basis.

In the present paper, the X-ray structures and variable-temperature solution-state NMR behavior of a series of new bicyclic oxyphosphoranes, 1-4, varying in ring size are reported. Each of the four compounds subjected to X-ray analysis contains the 5,5-dimethyldioxaphosphorinane ring which allows structural comparison as the other ring component is varied from five- to seven-membered.



(20) Corriu, R. J. P. *Phosphorus Sulfur* **1986**, *27*, 1 and references cited therein.

(21) Mikolajczyk, M.; Krzywanski, J.; Ziemnicka, B. *Tetrahedron Lett.* **1975**, 1607.

(22) Abdou, W. M.; Denney, D. B.; Denney, D. Z.; Pastor, S. D. *Phosphorus Sulfur* **1985**, *22*, 99.

## Experimental Section

Chemicals were obtained from Aldrich, Fisher Scientific, or Fluka and used without further purification. Solvents were of HPLC grade (Fisher Scientific). Further purification was done according to standard procedures.<sup>23a,b</sup>

<sup>1</sup>H and <sup>13</sup>C NMR spectra were recorded on a Varian Associates XL 300 FT-NMR or a Varian Associates XL 200 FT-NMR. <sup>31</sup>P NMR spectra were recorded on the Varian Associates XL 300 FT-NMR spectrometer. Chemical shifts for <sup>31</sup>P NMR spectra were obtained by setting triphenyl phosphate ( $\text{CDCl}_3$ ) at  $-18.0$  ppm<sup>23c</sup> and are referenced to 85%  $\text{H}_3\text{PO}_4$  with negative shifts upfield. Temperature calibration was accomplished by using an ethylene glycol sample with a calibration error at  $\pm 0.5$  °C.

**Syntheses.** **2-Chloro-5,5-dimethyl-1,3,2-dioxaphosphorinane,  $(\text{Me}_2\text{C}_3\text{H}_4\text{O}_2)\text{PCl}$  (5)**<sup>24</sup> and **2-Phenyl-5,5-dimethyl-1,3,2-dioxaphosphorinane,  $(\text{Me}_2\text{C}_3\text{H}_4\text{O}_2)\text{PPh}$  (6)**.<sup>25</sup> These phosphorinanes were prepared by literature methods; some properties are listed here. **5**: bp  $36$  °C (0.6 mm) (lit.<sup>24</sup> bp  $77$  °C (25 mm)); <sup>1</sup>H NMR ( $\text{CDCl}_3$ , ppm) 0.82 (s, 3 H,  $\text{CH}_3$  (e)), 1.26 (s, 3 H,  $\text{CH}_3$  (a)), 3.55 (t, 2 H,  $\text{OCH}_2$  (e)), 4.30 (dd, 2 H,  $\text{OCH}_2$  (a)); <sup>31</sup>P NMR ( $\text{CDCl}_3$ , ppm) 147.54. **6**: mp  $75$  °C (lit.<sup>25</sup> mp  $75$  °C); <sup>1</sup>H NMR ( $\text{CDCl}_3$ , ppm) 0.58 (s, 3 H,  $\text{CH}_3$ ), 1.33 (s, 3 H,  $\text{CH}_3$ ), 3.49 (t, 2 H,  $\text{OCH}_2$ ), 3.73 (dd, 2 H,  $\text{OCH}_2$ ), 7.15-7.60 (m, 5 H, H (Ar)); <sup>13</sup>C NMR ( $\text{CDCl}_3$ , ppm) 22.61, 22.67 ( $\text{C}(\text{CH}_3)_2$ ), 33.5 ( $\text{C}(\text{CH}_3)_2$ ), 71.50 (d, <sup>2</sup>J (P-O-C) = 3.5 Hz,  $\text{OCH}_2$ ), 128.8 (d), 129.15, 129.19, 129.45 ( $\text{C}(\text{Ar})$ ); <sup>31</sup>P NMR ( $\text{CDCl}_3$ , ppm) 144.96.

**2-(2,6-Dimethylphenoxy)-5,5-dimethyl-1,3,2-dioxaphosphorinane,  $(\text{Me}_2\text{C}_3\text{H}_4\text{O}_2)\text{P}(\text{O-Xyl})$  (7)**. To a solution of 2-chloro-5,5-dimethyl-1,3,2-dioxaphosphorinane (**5**) (64.80 g, 0.385 mol) and 2,6-dimethylphenol (47.00 g, 0.385 mol) in diethyl ether (300 mL) was added dropwise a solution of triethylamine (40.00 g, 0.396 mol) in diethyl ether over a period of 1 h under a nitrogen atmosphere at  $20$  °C. The mixture was stirred for 8 h and then filtered by using Schlenk techniques.<sup>26</sup> The precipitate was washed with  $2 \times 50$  mL of diethyl ether. The solvent was distilled off from the combined filtrate, and the residue distilled in vacuo to give **7** as an oil, bp  $129$  °C (0.8 mm) (80.00 g, 82%). <sup>1</sup>H NMR ( $\text{CDCl}_3$ , ppm): 0.82 (s, 3 H,  $\text{OCH}_2\text{C}(\text{CH}_3)_2$ ), 1.33 (s, 3 H,  $\text{OCH}_2\text{C}(\text{CH}_3)_2$ ), 2.32 (s, 6 H,  $\text{OC}_6\text{H}_3(\text{CH}_3)_2$ ), 3.50 (t, 2 H,  $\text{OCH}_2$ ), 4.47 (d, 2 H,  $\text{OCH}_2$ ), 6.90-7.10 (m, 3 H, H(Ar)). <sup>13</sup>C NMR ( $\text{CDCl}_3$ , ppm): 17.55, ( $\text{OC}_6\text{H}_3(\text{CH}_3)_2$ ), 22.45, 22.78 ( $\text{C}(\text{CH}_3)_2$ ), 32.86 ( $\text{C}(\text{CH}_3)_2$ ), 69.27 ( $\text{OCH}_2$ ), 123.74, 128.61, 130.41 ( $\text{C}(\text{Ar})$ ). <sup>31</sup>P NMR ( $\text{CDCl}_3$ , ppm): 117.64. Anal. Calcd for  $\text{C}_{13}\text{H}_{19}\text{O}_3\text{P}$ : C, 61.42; H, 7.48. Found: C, 61.41; H, 7.56.

**(2,2-Dimethylpropanediyl-1,3-dioxy)(1,2-diphenylethenediyl-1,2-dioxy)(2,6-dimethylphenoxy)phosphorane,  $(\text{Me}_2\text{C}_3\text{H}_4\text{O}_2)(\text{Xyl-O})\text{P}(\text{O}_2\text{C}_2\text{Ph}_2)$  (1)**. 2-(2,6-Dimethylphenoxy)-5,5-dimethyl-1,3,2-dioxaphosphorinane (**7**) (1.34 g, 5.27 mmol) and benzil (1.11 g, 5.28 mmol) were heated neat at  $120$  °C for 10 min under an atmosphere of nitrogen. After cooling down, the mixture was dissolved in diethyl ether (40 mL). Slow evaporation of the solvent at  $20$  °C afforded **1** as colorless crystals, mp  $116$ - $118$  °C (1.80 g, 73%). <sup>1</sup>H NMR ( $\text{CDCl}_3$ , ppm): 1.07 (s, 3 H,  $\text{CH}_2\text{C}(\text{CH}_3)_2$ ), 1.24 (s, 3 H,  $\text{CH}_2\text{C}(\text{CH}_3)_2$ ), 2.32 (d,  $J = 1.5$  Hz, 6 H,  $\text{C}_6\text{H}_3(\text{CH}_3)_2$ ), 4.00 (dd, <sup>3</sup>J (P- $\text{H}_B$ ) = 20.2 Hz, <sup>2</sup>J ( $\text{H}_A$ - $\text{H}_B$ ) = 10.9 Hz, 2 H,  $\text{H}_B$ ), 4.21 (dd, <sup>3</sup>J (P- $\text{H}_A$ ) = 16.3 Hz, <sup>2</sup>J ( $\text{H}_A$ - $\text{H}_B$ ) = 11.1 Hz, 2 H,  $\text{H}_A$ ), 6.90-7.30 (m, 13 H, H (Ar)). <sup>31</sup>P NMR ( $\text{C}_6\text{D}_6$ , ppm):  $-53.55$ . Variable-temperature <sup>1</sup>H NMR spectra ( $-95$  to  $+98$  °C; toluene- $d_6$ ) did not show any significant change except for broadening of signals at temperatures below  $-78$  °C. Anal. Calcd for  $\text{C}_{27}\text{H}_{29}\text{O}_5\text{P}$ : C, 69.83; H, 6.25. Found: C, 69.78; H, 6.22.

**(2,2-Dimethylpropanediyl-1,3-dioxy)(3,5-di-*tert*-butyl-1,2-phenylene-dioxy)(2,6-dimethylphenoxy)phosphorane,  $(\text{Me}_2\text{C}_3\text{H}_4\text{O}_2)(\text{Xyl-O})\text{P}(\text{O}_2\text{C}_6\text{H}_2\text{-}t\text{-Bu}_2)$  (2)**. 3,5-Di-*tert*-butyl quinone (1.85 g, 8.40 mmol) was added to 2-(2,6-dimethylphenoxy)-5,5-dimethyl-1,3,2-dioxaphosphorinane (**7**) (2.14 g, 8.42 mmol) under a nitrogen atmosphere. An exothermic reaction ensued. The mixture was kept at  $100$  °C for 10 min, cooled, and dissolved in a diethyl ether (35 mL) and hexane (10 mL) mixture. Slow evaporation of the solvent afforded **2** as a crystalline material, mp  $88$ - $90$  °C (3.00 g, 75%). <sup>1</sup>H NMR ( $\text{C}_6\text{D}_5\text{CD}_3$ , ppm): 0.61

(23) (a) Riddick, J. A.; Bunger, W. B., Eds. *Organic Solvents*. In *Physical Methods in Organic Chemistry*; Weissberger, Wiley Interscience: New York, 1970; Vol. 11. (b) Vogel, A. I. *Textbook of Practical Organic Chemistry*; Lingman: London, 1978. (c) Emsley, J.; Hall, D. *The Chemistry of Phosphorus*; Wiley: New York, 1976, p 82.

(24) (a) Zwierzak, A. *Can. J. Chem.* **1967**, *45*, 2501. (b) Lucas, H. J.; Mitchell, F. W., Jr.; Scully, C. N. *J. Am. Chem. Soc.* **1950**, *72*, 5491.

(25) (a) Gagnaire, D.; Robert, J. B.; Verrier, J. *Bull. Soc. Chim. Fr.* **1968**, 2392. (b) Arshinova, R. P.; Gubaidullin, R. N.; Ibragimova, S. D.; Mukmenev, E. T. *Izv. Akad. Nauk. SSSR Ser. Khim.* **1979**, 1518.

(26) Shriver, D. F.; Drezdson, M. A. *The Manipulation of Air-Sensitive Compounds*, 2nd ed.; Wiley-Interscience: New York, 1986.

(s, 3 H,  $\text{CH}_2(\text{CH}_3)$ ), 0.76 (s, 3 H,  $\text{CH}_2(\text{CH}_3)$ ), 1.19 (s, 9 H,  $\text{C}(\text{CH}_3)_3$ ), 1.26 (s, 9 H,  $\text{C}(\text{CH}_3)_3$ ), 2.31 (s, 6 H,  $\text{OC}_6\text{H}_3(\text{CH}_3)_2$ ), 3.73 (dd, 3J(P-H<sub>B</sub>) = 19.0 Hz, <sup>2</sup>J(H<sub>A</sub>-H<sub>B</sub>) = 11.2 Hz, 2 H,  $\text{OCH}_2$ , H<sub>B</sub>), 3.90 (dd, <sup>3</sup>J(P-H<sub>A</sub>) = 17.3 Hz, <sup>2</sup>J(H<sub>A</sub>-H<sub>B</sub>) = 10.7 Hz, 2 H,  $\text{OCH}_2$ , H<sub>A</sub>), 6.70–7.20 (m, 5 H, H(Ar)). <sup>31</sup>P NMR ( $\text{C}_6\text{D}_6$ , ppm): -51.3. Variable <sup>1</sup>H NMR spectra were recorded in the range -90 to +90 °C. It was observed that the  $\text{OCH}_2$  peaks broadened significantly below -70 °C. Peaks due to  $\text{OC}_6\text{H}_3(\text{CH}_3)_2$ ,  $\text{C}(\text{CH}_3)_3$  and  $\text{CH}_2(\text{CH}_3)_2$  also broadened. However, neither the low-temperature limit nor the high-temperature limit could be reached. Anal. Calcd for  $\text{C}_{27}\text{H}_{39}\text{O}_5\text{P}$ : C, 68.35; H, 8.23. Found: C, 68.27; H, 8.33.

**(Biphenylene-2,2'-dioxy)(2,2-dimethylpropanediyl-1,3-dioxy)(2,6-dimethylphenoxy)phosphorane, (Me<sub>2</sub>C<sub>3</sub>H<sub>4</sub>O<sub>2</sub>)(Xyl-O)P(O<sub>2</sub>C<sub>12</sub>H<sub>8</sub>)-CH<sub>2</sub>Cl<sub>2</sub> (3).** To a solution of 2-(2,6-dimethylphenoxy)-5,5-dimethyl-1,3,2-dioxaphosphorinane (7) (3.47 g, 13.6 mmol) and 2,2'-biphenol (2.53 g, 13.6 mmol) in diethyl ether (50 mL) maintained at -60 °C was added dropwise a solution of *N*-chlorodiisopropylamine (1.85 g, 13.7 mmol) over a period of 15 min with continuous stirring under an atmosphere of nitrogen. The mixture was brought to 20 °C, stirred for 6 h, and filtered by using Schlenk techniques.<sup>26</sup> Most of compound 3 precipitated along with diisopropylamine hydrochloride (7.5 g). A portion of this precipitate (2.5 g) was washed quickly with water (3 × 15 mL) and dried in vacuo (0.2–0.3 mm/30 °C/6 h) to afford 1.7 g of 3 as a white powder (overall yield 85%), mp 192–194 °C. <sup>1</sup>H NMR ( $\text{C}_6\text{D}_5\text{CD}_3$ , ppm) at 30 °C: 0.66 (s, 6 H,  $\text{CH}_2\text{C}(\text{CH}_3)_2$ ), 2.26 (s, 6 H,  $\text{OC}_6\text{H}_3(\text{CH}_3)_2$ ), 3.69 (d, 3J(P-H) = 18.8 Hz, 4 H,  $\text{OCH}_2$ ), 6.60–7.40 (m, 11 H, H(Ar)). <sup>31</sup>P NMR ( $\text{CDCl}_3$ , ppm): -60.0 ppm. <sup>13</sup>C NMR ( $\text{C}_6\text{D}_5\text{CD}_3$ , ppm) at 20 °C: 17.10 (s,  $\text{OC}_6\text{H}_3(\text{CH}_3)_2$ ), 24.39 (s,  $\text{CH}_2\text{C}(\text{CH}_3)_2$ ), 32.70 (d, <sup>3</sup>J(P-C) = 3.6 Hz,  $\text{C}(\text{CH}_3)_2$ ), 75.45 (d, <sup>2</sup>J(P-C) = 8.3 Hz). Aromatic carbons are mostly masked by toluene-*d*<sub>6</sub> peaks. Variable temperature <sup>13</sup>C NMR ( $\text{C}_6\text{D}_5\text{C}-\text{D}_3$ ) spectra were recorded in the range -79 to +20 °C. An activation energy ( $\Delta G^\ddagger$ ) of 11.1 kcal/mol was calculated<sup>28</sup> from the peaks due to  $\text{OCH}_2$  carbons ( $\Delta\nu = 138$  Hz and  $T_c = 238$  K). An approximate value of 11.3 kcal/mol was also obtained from the  $\text{OC}_6\text{H}_3(\text{CH}_3)_2$  region ( $\Delta\nu = 17.1$  Hz and  $T_c = 223$  K). Anal. Calcd for  $\text{C}_{25}\text{H}_{27}\text{O}_5\text{P}$ : C, 68.49; H, 6.16. Found: C, 68.64; H, 6.21.

Crystals of 3 suitable for X-ray diffraction studies were grown as a dichloromethane solvate from dichloromethane.

**Bis(2,2-dimethylpropanediyl-1,3-dioxy)(phenyl)phosphorane, (Me<sub>2</sub>C<sub>3</sub>H<sub>4</sub>O<sub>2</sub>)<sub>2</sub>PPh (4).** This compound has been reported before.<sup>19,27</sup> In the present work, it was prepared by the method of Antczak et al.<sup>27</sup> In 60% yield, mp 100–103 °C (lit.<sup>27</sup> mp 69–72 °C). <sup>1</sup>H NMR ( $\text{C}_6\text{D}_5\text{CD}_3$ , ppm) at 20 °C: 0.79 (s, 12 H,  $\text{CH}_3$ ), 3.64 (d, 3J(P-H) = 16.9 Hz), 6.90–7.95 (m, 5 H, H(Ar)). <sup>31</sup>P NMR ( $\text{C}_6\text{D}_6$ , ppm): -49.15 (lit. -49.0,<sup>19</sup> -48.4<sup>27</sup> ppm). Anal. Calcd for  $\text{C}_{16}\text{H}_{25}\text{O}_4\text{P}$ : C, 61.54; H, 8.01. Found: C, 61.90; H, 8.29.

**X-ray Studies.** All X-ray crystallographic studies were done with use of an Enraf-Nonius CAD4 diffractometer and graphite monochromated molybdenum radiation ( $\lambda\text{K}\alpha = 0.71073$  Å) at an ambient temperature of 23 ± 2 °C. Details of the experimental procedures have been described previously.<sup>29</sup>

Crystals were mounted in thin-walled glass capillaries which were sealed. For 1 and 2 this measure was precautionary. For 3 and 4 it was necessary in order to retard degradation of the crystals. Data was collected using the  $\theta - 2\theta$  scan mode. No corrections were made for absorption. The structures were solved by use of direct methods and difference Fourier techniques and were refined by full-matrix least squares.<sup>30</sup> All computations were performed on a Microvax II computer using the Enraf-Nonius SDP system of programs.

**X-ray Study for (Me<sub>2</sub>C<sub>3</sub>H<sub>4</sub>O<sub>2</sub>)(Xyl-O)P(O<sub>2</sub>C<sub>2</sub>Ph<sub>2</sub>) (1).** The colorless crystal used for the X-ray study was cut from a polyfaceted rod and had dimensions of 0.30 × 0.38 × 0.50 mm.

**Crystal Data.** 1:  $\text{C}_{27}\text{H}_{39}\text{O}_5\text{P}$ , monoclinic space group  $P2_1/n$  (alternate setting of  $P2_1/c$  [ $C2_h^2$  - no. 14]<sup>31</sup>),  $a = 10.633$  (3),  $b = 17.648$  (3),  $c = 13.601$  (1) Å,  $\beta = 102.47$  (1)°,  $Z = 4$ , and  $\mu_{\text{MoK}\alpha} = 1.386$  cm<sup>-1</sup>. A total of 4368 independent reflections (+h, +k, ±l;  $3^\circ \leq 2\theta_{\text{MoK}\alpha} \leq 50^\circ$ ) was collected.

The 33 independent non-hydrogen atoms were refined anisotropically. The 29 independent hydrogen atoms were included in the refinement as fixed isotropic scatterers (ideal positions or regularized xylol methyl

group hydrogen atoms from difference Fourier coordinates). The final agreement factors<sup>32</sup> were  $R = 0.037$  and  $R_w = 0.050$  for the 2816 reflections having  $I \geq 3\sigma_I$ .

**X-ray Study for (Me<sub>2</sub>C<sub>3</sub>H<sub>4</sub>O<sub>2</sub>)(Xyl-O)P(O<sub>2</sub>C<sub>6</sub>H<sub>2</sub>-*t*-Bu<sub>2</sub>) (2).** Only crystals of 2 that were poor in quality could be obtained. The colorless, irregular crystal used for the X-ray study was cut from a polycrystalline mass and had approximate dimensions of 0.25 × 0.45 × 0.50 mm.

**Crystal Data.** 2:  $\text{C}_{27}\text{H}_{39}\text{O}_5\text{P}$ , monoclinic space group  $P2_1/n$ ,  $a = 10.459$  (2),  $b = 12.712$  (1),  $c = 19.949$  (2) Å,  $\beta = 95.28$  (1)°,  $Z = 4$ , and  $\mu_{\text{MoK}\alpha} = 1.317$  cm<sup>-1</sup>. A total of 2447 independent reflections (+h, +k, ±l;  $3^\circ \leq 2\theta_{\text{MoK}\alpha} \leq 40^\circ$ ) was collected. The crystal suffered serious degradation during data collection. An isotropic decay correction was applied (correction factors from 1.000 to 1.360).

During solution of the structure, high isotropic thermal parameters for the three pendant *t*-Bu carbon atoms, C42–C44, suggested disorder in this portion of the molecule. Attempts to locate two sets of positions for these atoms proved unsuccessful, and they were kept as isotropic scatterers for the rest of the refinement. The remaining 30 independent non-hydrogen atoms were refined anisotropically. The 9 hydrogen atoms associated with the poorly defined *t*-Bu group and the 6 xylol methyl group hydrogen atoms were omitted from the refinement. The remaining 24 independent hydrogen atoms were treated as described for 1. The final agreement factors<sup>32</sup> were  $R = 0.093$  and  $R_w = 0.104$  for the 1418 reflections having  $I \geq 3\sigma_I$ .

**X-ray Study for (Me<sub>2</sub>C<sub>3</sub>H<sub>4</sub>O<sub>2</sub>)(Xyl-O)P(O<sub>2</sub>C<sub>12</sub>H<sub>8</sub>)-CH<sub>2</sub>Cl<sub>2</sub> (3).** Large colorless brick-like crystals of 3 became opaque when left in an open dish, possibly due to loss of solvent. A clear crystal cut to dimensions of 0.30 × 0.35 × 0.49 mm and mounted in a capillary which was sealed was used for the data collection, but it was badly frosted by the end of data collection.

**Crystal Data.** 3:  $\text{C}_{25}\text{H}_{27}\text{O}_5\text{P}\cdot\text{CH}_2\text{Cl}_2$ , monoclinic space group  $P2_1/n$ ,  $a = 9.655$  (4),  $b = 11.662$  (4),  $c = 22.720$  (6) Å,  $\beta = 94.28$  (3)°,  $Z = 4$ , and  $\mu_{\text{MoK}\alpha} = 3.498$  cm<sup>-1</sup>. A total of 2899 independent reflections (+h, +k, ±l;  $3^\circ \leq 2\theta_{\text{MoK}\alpha} \leq 43^\circ$ ) was collected. The crystal suffered serious degradation during data collection. An isotropic decay correction was applied (correction factors from 1.000 to 1.437).

The 34 independent non-hydrogen atoms were refined anisotropically. The 29 independent hydrogen atoms were treated as described for 1. The final agreement factors<sup>32</sup> were  $R = 0.050$  and  $R_w = 0.062$  for the 1856 reflections having  $I \geq 3\sigma_I$ .

**X-ray Study for (Me<sub>2</sub>C<sub>3</sub>H<sub>4</sub>O<sub>2</sub>)<sub>2</sub>PPh (4).** Colorless, large, rectangular, tab-shaped crystals of 4 are deliquescent. A crystal, cut approximately to the shape of a triangular prism with an edge length of 0.45 mm and a height of 0.36 mm and mounted inside of a capillary which was sealed, remained stable throughout the X-ray study. Although the unit cell dimensions (two edges approximately equal) suggested a tetragonal crystal system, the diffraction symmetry (*mmm*) did not support this assignment.

**Crystal Data.** 4:  $\text{C}_{16}\text{H}_{25}\text{O}_4\text{P}$ , uniquely determined orthorhombic space group  $Pbcn$  [ $D_{2h}^4$  - no. 60],<sup>33</sup>  $a = 13.922$  (4),  $b = 11.050$  (2),  $c = 11.020$  (3) Å,  $Z = 4$ , and  $\mu_{\text{MoK}\alpha} = 1.682$  cm<sup>-1</sup>. A total of 1489 independent reflections (+h, +k, +l;  $3^\circ \leq 2\theta_{\text{MoK}\alpha} \leq 50^\circ$ ) was measured.

During solution of the structure, two sets of positions (A and B) were found for the two independent oxygen atoms, O1 and O2. These 4 atoms were refined anisotropically in half occupancy. The remaining 10 independent non-hydrogen atoms were refined anisotropically. Because of the disorder in the oxygen atoms, the hydrogen atoms bonded to the adjacent C1 and C2 atoms were omitted from the refinement. The 9 remaining independent hydrogen atoms were treated as described for 1. The final agreement factors<sup>32</sup> were  $R = 0.062$  and  $R_w = 0.088$  for the 905 reflections having  $I \geq 3\sigma_I$ .

## Results

The atom labeling scheme for 1 is shown in the ORTEP plot of Figure 1, while selected bond lengths and angles are given in Table I. The corresponding information for compounds 2–4 is given in Figures 2, 3, and 5 and in Tables II–IV. For all four compounds, atomic coordinates, anisotropic thermal parameters, a complete table of bond lengths and angles for nonhydrogen atoms, and hydrogen atom parameters are provided as supplementary material.

## Discussion

**Synthesis and Basic Structures.** The new bicyclic pentaoxyphosphoranes 1–3 were prepared by the oxidative addition of a

(27) Antczak, S.; Bone, S. A.; Brierly, J.; Trippett, S. J. *Chem. Soc., Perkin I* 1977, 278.

(28) Calculated from the equation:  $\Delta G_c^\ddagger = 4.57 \times 10^{-3} T_c(10.32 + \log(T_c \sqrt{2/\pi\Delta\nu}))$  following Kessler, H. *Angew. Chem.* 1970, 82, 237, and Buono, G.; Llinas, J. R. *J. Am. Chem. Soc.* 1981, 103, 4532.

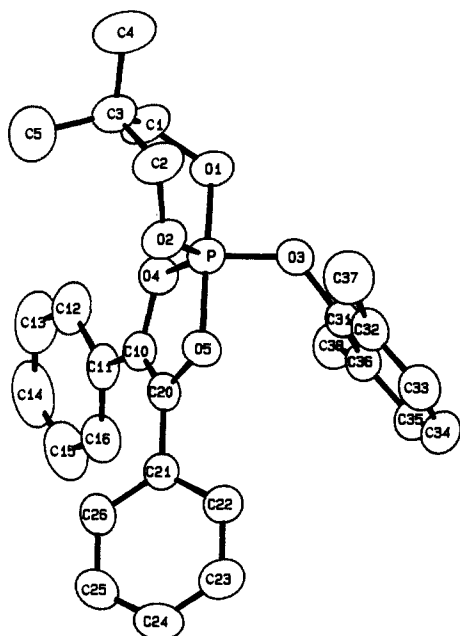
(29) Sau, A. C.; Day, R. O.; Holmes, R. R. *Inorg. Chem.* 1981, 20, 3076.

(30) The function minimized was  $\sum w(|F_o| - |F_c|)^2$ , where  $w^{1/2} = 2F_o L p / \sigma_I$ .

(31) *International Tables for X-Ray Crystallography*; Kynoch: Birmingham, England, 1969; Vol. 1, p 99.

(32)  $R = \sum ||F_o| - |F_c|| / \sum |F_o|$  and  $R_w = \{\sum w(|F_o| - |F_c|)^2 / \sum w|F_o|^2\}^{1/2}$ .

(33) Reference 31, p 149.



**Figure 1.** ORTEP plot of  $(\text{Me}_2\text{C}_3\text{H}_4\text{O}_2)(\text{Xyl-O})\text{P}(\text{O}_2\text{C}_2\text{Ph}_2)$  (**1**) with thermal ellipsoids at the 50% probability level. Hydrogen atoms are omitted for clarity.

**Table 1.** Selected Distances (Å) and Angles (deg) for  $(\text{Me}_2\text{C}_3\text{H}_4\text{O}_2)(\text{Xyl-O})\text{P}(\text{O}_2\text{C}_2\text{Ph}_2)$  (**1**)<sup>a</sup>

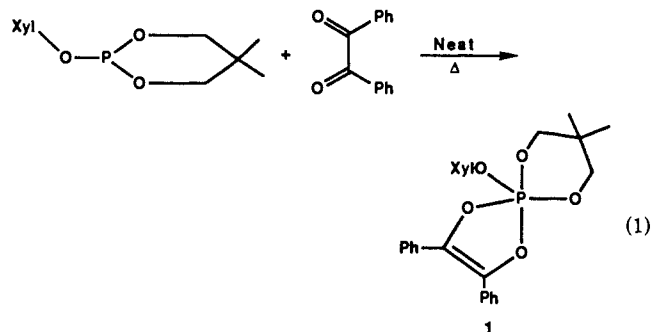
atom 1	atom 2	distance	atom 1	atom 2	distance
P	O1	1.635 (2)	O1	C1	1.439 (3)
P	O2	1.595 (2)	O2	C2	1.455 (3)
P	O3	1.599 (2)	O3	C31	1.406 (3)
P	O4	1.629 (2)	O4	C10	1.403 (3)
P	O5	1.707 (2)	O5	C20	1.372 (3)
C1	C3	1.540 (3)	C10	C20	1.339 (3)
C2	C3	1.519 (4)			

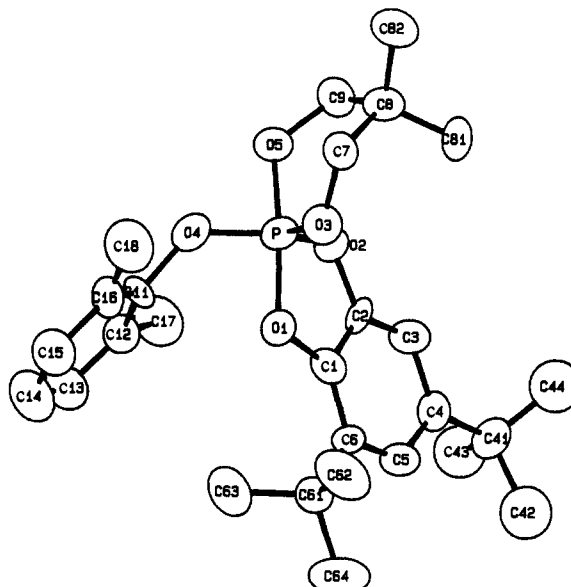
atom 1	atom 2	atom 3	angle	atom 1	atom 2	atom 3	angle
O1	P	O2	95.98 (9)	O3	P	O5	92.25 (9)
O1	P	O3	86.72 (9)	O4	P	O5	88.60 (8)
O1	P	O4	89.98 (8)	P	O1	C1	118.3 (2)
O1	P	O5	177.48 (8)	P	O2	C2	120.4 (2)
O2	P	O3	118.59 (9)	P	O3	C31	127.5 (1)
O2	P	O4	119.59 (9)	P	O4	C10	115.8 (1)
O2	P	O5	86.53 (8)	P	O5	C20	113.7 (1)
O3	P	O4	121.75 (8)	O1	C1	C3	111.3 (2)
C1	C3	C2	108.1 (2)	O2	C2	C3	111.5 (2)
O4	C10	C20	110.2 (2)	O5	C20	C10	111.7 (2)

<sup>a</sup> Estimated standard deviations in parentheses. The atom labeling scheme is shown in Figure 1.

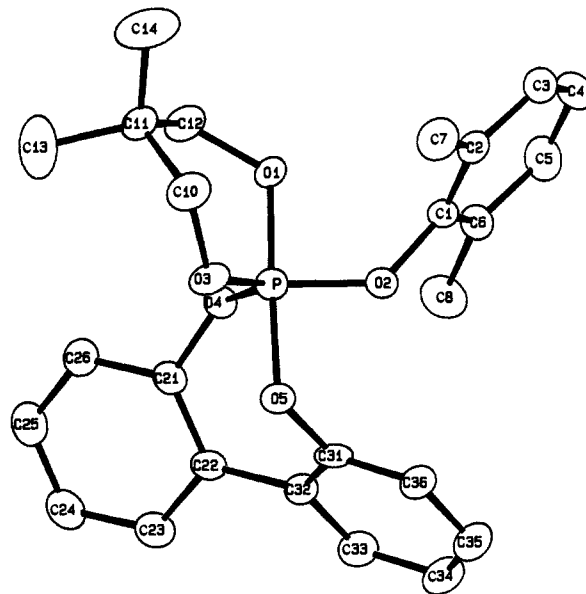
quinone or a diol to the cyclic phosphite **7** in yields of 60–80%. A typical synthesis is illustrated in eq 1 for the formation of **1**.



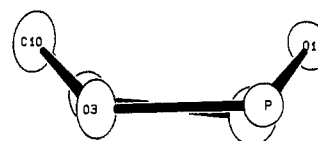
X-ray analysis of the cyclic phosphoranes **1–4** revealed trigonal bipyramidal geometries with the ring systems spanning axial-equatorial sites and the oxygen atom of the dimethylphenoxy group in an equatorial position. The six-membered phosphorinane rings in all of these compounds have a boat conformation with an axial



**Figure 2.** ORTEP plot of  $(\text{Me}_2\text{C}_3\text{H}_4\text{O}_2)(\text{Xyl-O})\text{P}(\text{O}_2\text{C}_6\text{H}_2-t\text{-Bu}_2)$  (**2**) with thermal ellipsoids at the 50% probability level. The isotropically refined C42, C43, and C44 are represented as spheres of arbitrary radius. Hydrogen atoms are omitted for clarity.



**Figure 3.** ORTEP plot of the  $(\text{Me}_2\text{C}_3\text{H}_4\text{O}_2)(\text{Xyl-O})\text{P}(\text{O}_2\text{C}_{12}\text{H}_8)$  moiety in **3** with thermal ellipsoids at the 30% probability level. Hydrogen atoms are omitted for clarity.



**Figure 4.** ORTEP plot showing the boat conformation of the six-membered phosphorinane ring in **3**.

oxygen atom and the carbon atom opposite it at the prow and the stern of the boat. A representative boat (for compound **3**) is shown in Figure 4. The other ring component of this phosphorane is seven-membered which resides in a "rowboat" conformation (Figure 3).

It is apparent that the conformation and site occupancy of the six-membered dioxaphosphorinane ring is not significantly affected by the compositional changes or the size of the ring of the associated cyclic system in this series of phosphoranes. The boat conformation observed in **1–4** is of the type found in phosphoranes **A**<sup>15</sup> and **B**<sup>16</sup> depicted in the Introduction and is the one discussed

**Table II.** Selected Distances (Å) and Angles (deg) for (Me<sub>2</sub>C<sub>3</sub>H<sub>4</sub>O<sub>2</sub>)(Xyl-O)P(O<sub>2</sub>C<sub>6</sub>H<sub>2</sub>-*t*-Bu<sub>2</sub>)(2)<sup>a</sup>

atom 1	atom 2	distance	atom 1	atom 2	distance
P	O1	1.713 (9)	O1	C1	1.39 (2)
P	O2	1.628 (9)	O2	C2	1.37 (1)
P	O3	1.587 (9)	O3	C7	1.48 (2)
P	O4	1.598 (9)	O4	C11	1.43 (1)
P	O5	1.634 (9)	O5	C9	1.42 (2)
C1	C2	1.40 (2)	C7	C8	1.52 (2)
			C8	C9	1.54 (2)

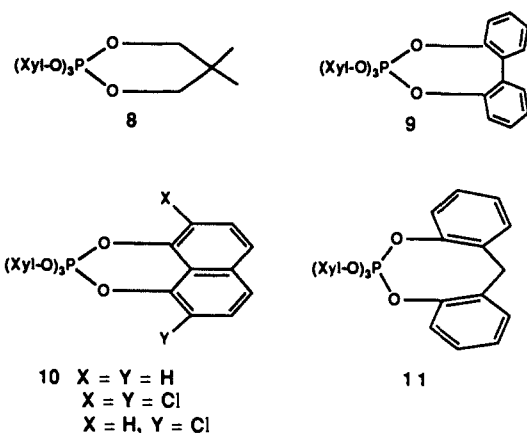
  

atom 1	atom 2	atom 3	angle	atom 1	atom 2	atom 3	angle
O1	P	O2	90.3 (4)	O3	P	O5	96.7 (5)
O1	P	O3	88.2 (5)	O4	P	O5	85.8 (5)
O1	P	O4	89.9 (4)	P	O1	C1	113.2 (7)
O1	P	O5	174.6 (5)	P	O2	C2	114.5 (8)
O2	P	O3	115.6 (5)	P	O3	C7	121.6 (8)
O2	P	O4	125.3 (5)	P	O4	C11	130.2 (8)
O2	P	O5	89.6 (4)	P	O5	C9	122.4 (8)
O3	P	O4	119.1 (5)	O3	C7	C8	112 (1)
C7	C8	C9	107 (1)	O5	C9	C8	114 (1)
O1	C1	C2	108 (1)	O2	C2	C1	112 (1)

<sup>a</sup> Estimated standard deviations in parentheses. The atom labeling scheme is shown in Figure 2.

by Trippett<sup>18a</sup> as most favorable in allowing the lone pair of the equatorial heteroatom bonded to phosphorus to reside near the equatorial plane. The latter orientation allows maximum  $\pi$  bonding with phosphorus d orbitals that helps stabilize an apical-equatorial orientation relative to a diequatorial ring arrangement.

The degree to which this is achieved is shown in Table V where the dihedral angle between the plane containing the atoms P-O<sub>eq</sub>-C and the equatorial plane is listed for each ring and xylyloxy group for 1-4. These values are compared with corresponding information on the monocyclic pentaoxyphosphoranes 8-11 discussed in the following article.<sup>5</sup> The ranges of dihedral angles



in the bicyclic systems, 1-4, for the six-membered rings, five-membered rings, and xylyloxy groups are comparable and tend to approach the desired 90° value. It is noted that the "rowboat" conformation for the seven-membered ring in phosphorane 3 exhibits the lowest dihedral angle. The value of 56.1° for this angle for the six-membered ring in the monocyclic phosphorane 10 is significantly low. This is the only six-membered ring not in a boat conformation but rather it is in an "envelope" form that is an essentially planar structure with phosphorus acting as the flap atom.

Further analysis of the boat conformations of 1-4 show that they are all similar. The four atoms forming the base of the boat are coplanar to within  $\pm 0.037$ ,  $\pm 0.063$ , and  $\pm 0.048$  Å for compounds 1-3, respectively. For 4, these values are  $\pm 0.015$  and  $\pm 0.007$  for the A and B set of positions, respectively (see Figure 5 and later discussion). The five-membered rings in compounds 1 and 2 are essentially planar. For 1, atoms P, O4, O5, C10, and C20 are coplanar to within  $\pm 0.009$  Å. For 2, atoms P, O1, O2, C1, and C2 are coplanar to within  $\pm 0.060$  Å. For the seven-

**Table III.** Selected Distances (Å) and Angles (deg) for (Me<sub>2</sub>C<sub>3</sub>H<sub>4</sub>O<sub>2</sub>)(Xyl-O)P(O<sub>2</sub>C<sub>12</sub>H<sub>8</sub>)-CH<sub>2</sub>Cl<sub>2</sub>(3)<sup>a</sup>

atom 1	atom 2	distance	atom 1	atom 2	distance
P	O1	1.634 (3)	O1	C12	1.437 (6)
P	O2	1.604 (3)	O2	C1	1.412 (5)
P	O3	1.590 (4)	O3	C10	1.454 (7)
P	O4	1.616 (3)	O4	C21	1.399 (6)
P	O5	1.685 (4)	O5	C31	1.383 (6)
C10	C11	1.501 (8)	C11	C12	1.523 (8)
C21	C22	1.396 (7)	C22	C32	1.466 (7)
C31	C32	1.398 (7)			

atom 1	atom 2	atom 3	angle	atom 1	atom 2	atom 3	angle
O1	P	O2	89.9 (2)	O3	P	O5	84.4 (2)
O1	P	O3	95.2 (2)	O4	P	O5	92.9 (2)
O1	P	O4	90.1 (2)	P	O1	C12	119.3 (3)
O1	P	O5	176.8 (2)	P	O2	C1	129.9 (3)
O2	P	O3	124.7 (2)	P	O3	C10	122.3 (3)
O2	P	O4	117.8 (2)	P	O4	C21	130.9 (3)
O2	P	O5	87.8 (2)	P	O5	C31	119.8 (3)
O3	P	O4	117.2 (2)	O3	C10	C11	113.7 (4)
C10	C11	C12	108.2 (4)	O1	C12	C11	112.9 (4)
O4	C21	C22	122.7 (4)	C21	C22	C32	122.5 (4)
O5	C31	C32	119.2 (4)	C22	C32	C31	120.3 (5)

<sup>a</sup> Estimated standard deviations in parentheses. The atom labeling scheme is shown in Figure 3.

**Table IV.** Selected Distances (Å) and Angles (deg) for (Me<sub>2</sub>C<sub>3</sub>H<sub>4</sub>O<sub>2</sub>)<sub>2</sub>PPh(4)<sup>a</sup>

atom 1	atom 2	distance	atom 1	atom 2	distance
P	O1A	1.618 (5)	O1B	C1	1.435 (6)
P	O2A	1.681 (5)	O2A	C2	1.393 (7)
P	O1B	1.682 (5)	C2B	C2	1.430 (7)
P	O2B	1.624 (5)	C1	C3	1.511 (6)
P	C6	1.806 (5)	C2	C3	1.522 (6)
O1A	C1	1.395 (7)			

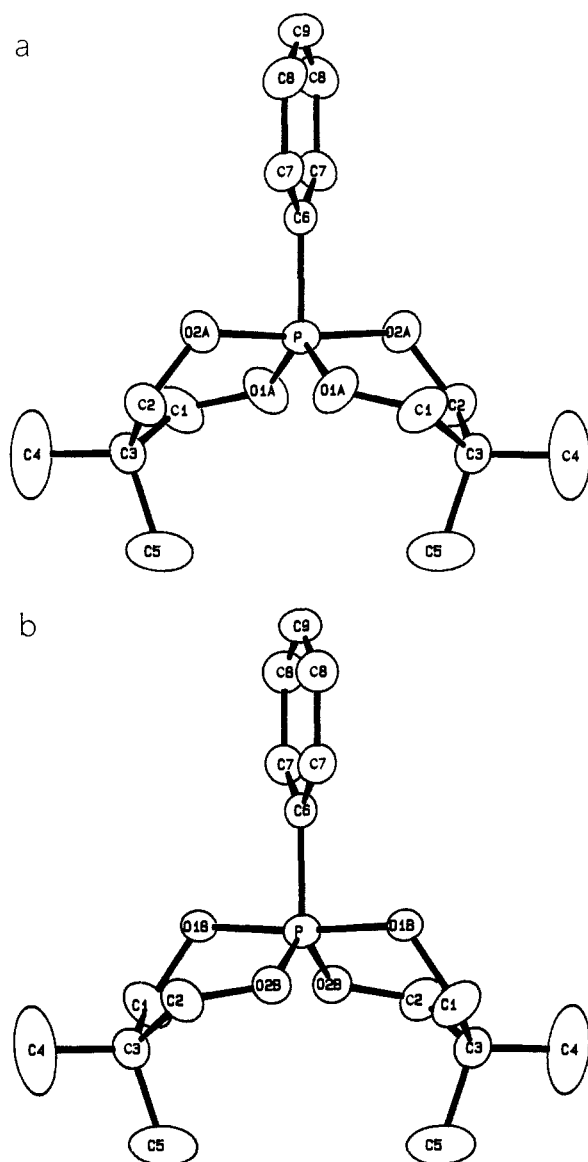
  

atom 1	atom 2	atom 3	angle	atom 1	atom 2	atom 3	angle
O1A	P	O1A'	119.7 (3)	O2A	P	O2A'	175.2 (3)
O1A	P	O2A	92.6 (3)	O1A	P	O2A'	89.8 (3)
O1A	P	C6	120.2 (2)	O2A	P	C6	87.6 (2)
O2B	P	C6	120.0 (2)	O2B	P	O2B'	120.1 (2)
P	O2A	C2	123.2 (4)	P	O1A	C1	126.9 (4)
O1B	P	O1B'	174.3 (2)	P	O1B	C1	119.6 (3)
O1B	P	O2B	92.8 (2)	P	O2B	C2	124.8 (4)
O1B	P	O2B'	90.0 (2)	O1A	C1	C3	114.4 (4)
O1B	P	C6	87.2 (2)	O1B	C1	C3	112.6 (4)
O2A	C2	C3	113.8 (4)	C1	C3	C2	109.7 (3)
O2B	C2	C3	111.9 (4)				

<sup>a</sup> Estimated standard deviations in parentheses. The atom labeling scheme is shown in Figure 5.

membered ring in 3, the atoms P, O4, C31, and C32 are coplanar to within  $\pm 0.011$  Å. Atoms C21, C22, and O5 are displaced from this plane in the same direction by 0.792, 0.706, and 0.709 Å, respectively, and the dihedral angle between this plane and the plane defined by P, O5, and C31 is 68.2°. The corresponding dihedral angle for the plane defined by O4, C21, C22, and C32 (coplanar to within  $\pm 0.050$  Å) is 38.6°.

It is instructive to compare the apical and equatorial P-O bond lengths for the various rings and the acyclic xylyloxy group. Table VI lists these values for the bicyclics 1-4 and the monocyclics 8-11. Average P-O bond lengths are plotted vs ring size in Figure 7. The values of the six-membered ring for 4 (disorder) and 10 (contains ring unsaturation) are excluded. As expected, the apical P-O bond lengths are uniformly longer than the corresponding equatorial values as ring size changes over the series. The larger values for apical and equatorial P-O lengths for the five-membered ring systems relative to the remainder of the series undoubtedly reflects in some measure the greater strain for these unsaturated rings when placed in a trigonal-bipyramidal environment compared to the strain encountered by the saturated phosphorinane ring as well as the larger rings. By the time the ring size is up to seven



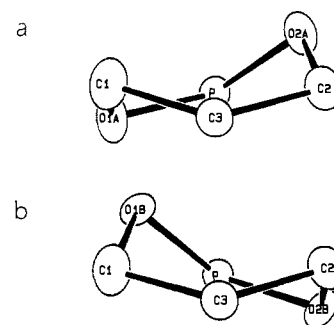
**Figure 5.** ORTEP plot of  $(\text{Me}_2\text{C}_3\text{H}_4\text{O}_2)_2\text{PPh}$  (**4**) with thermal ellipsoids at the 30% probability level. Atoms within a molecule with the same label are related by a crystallographic two-fold axis  $(-x, y, 1/2 - z)$ : (a) showing the A set of positions for the oxygen atoms and (b) showing the B set of positions for the oxygen atoms.

**Table V.** Dihedral Angles between  $\text{P}-\text{O}_{\text{eq}}-\text{C}$  Bonds and Equatorial Planes for Phosphoranes (deg)

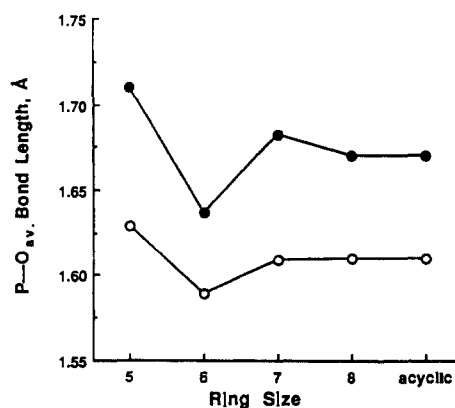
	ring size, no. atoms				xylyloxy group
	5	6	7	8	
Bicyclic Systems					
<b>1</b>	87.9	75.9			87.8
<b>2</b>	79.0	86.4			88.2
<b>3</b>		77.8	66.6		72.5
<b>4A<sup>a</sup></b>		83.0			
<b>4B<sup>a</sup></b>		80.1			
Monocyclic Systems					
<b>8</b>		83.6			66.2, 87.6
<b>9</b>			69.3		71.3, 88.1
<b>10</b>		56.1			76.1, 88.5
<b>11A<sup>b</sup></b>				76.9	78.0, 87.8
<b>11B<sup>b</sup></b>				81.0	81.8, 87.9

<sup>a</sup>Two sets of positions were obtained for the ring oxygen atoms that were refined in half occupancy. <sup>b</sup>Two independent molecules per unit cell.

or eight membered, we reason that ring flexibility is sufficient to allow the P–O bond lengths in the trigonal bipyramid (TBP) to approach those of the acyclic component. An especially

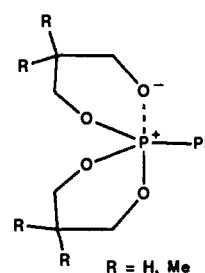


**Figure 6.** ORTEP plot showing the boat conformations of the six-membered phosphorane rings in **4**: (a) showing the A set of positions for the oxygen atoms and (b) showing the B set of positions for the oxygen atoms. The pseudo mirror plane which takes one set of oxygen atoms into the other and C1 into C2 passes through P and C3.



**Figure 7.** Average P–O bond length vs ring size for apical bonds (filled circle) and equatorial bonds (open circle) obtained from phosphoranes **1–3** and **8–11**, excluding the six-membered ring for **10**.

“strain-free” conformation is indicated for the boat form of the six-membered ring in the TBP since its average apical and equatorial P–O bond lengths are the shortest in this series of phosphorane compounds. This stability adds credence to the suggestion by McGall and McClelland<sup>34</sup> that the presence of six-membered rings in the hydrolysis of spiro oxyphosphoranes allows a very polar P–O bond to be retained prior to collision with a strong acid such as  $\text{H}_3\text{O}^+$ .



The average P–O bond lengths in Figure 7 agree well with those determined for other pentaoxyphosphoranes: **B**<sup>16</sup> discussed in the Introduction, pentaphenoxyphosphorane, **12**,<sup>35</sup> and the phenanthrene-substituted phosphorane, **13**.<sup>36</sup> The average P–O bond values for  $\text{P}(\text{O}^-\text{Ph})_5$  are 1.663 Å (apical) and 1.599 Å (equatorial).<sup>35</sup>

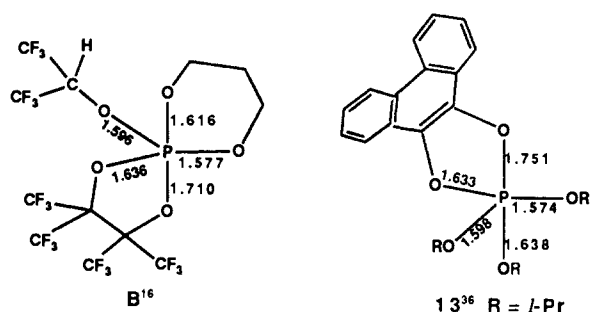
**Structural Distortions.** As often found,<sup>4,37</sup> structural distortions of phosphoranes usually can be referenced to the Berry pseudo-rotational coordinate.<sup>36</sup> The same is true for the present five-

(34) McGall, G. H.; McClelland, R. A. *J. Am. Chem. Soc.* **1985**, *107*, 5198.

(35) Sarma, R.; Ramirez, F.; McKeever, B.; Maracek, J. F.; Lee, S. *J. Am. Chem. Soc.* **1976**, *98*, 581.

(36) (a) Hamilton, W. C.; LaPlaca, S. J.; Ramirez, F. *J. Am. Chem. Soc.* **1965**, *87*, 127. (b) Spratley, R. D.; Hamilton, W. C.; Ladell, J. *J. Am. Chem. Soc.* **1967**, *89*, 2272.

(37) Reference 3, Chapter 2.



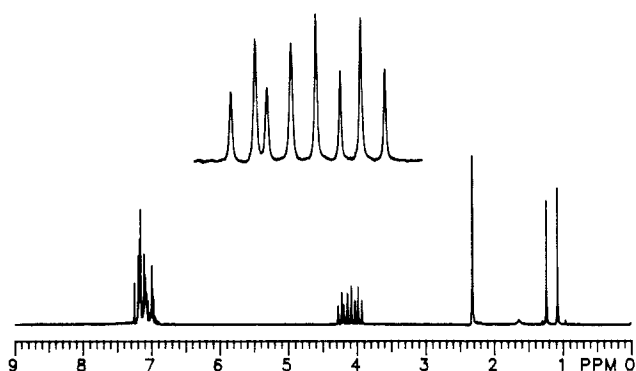
coordinated derivatives, although the distortions are modest. This comes about since the usual criteria for achieving a square or rectangular pyramidal geometry are not met. For bicyclics containing five-membered rings, ring unsaturation is required in both rings and like atoms must be bound to phosphorus in each of the rings.<sup>39,40</sup> Most likely, it will be difficult to find a bicyclic compound with six-membered rings with sufficient ring constraints to induce destabilization of the normally preferred trigonal-bipyramidal structure.

By use of the dihedral angle method<sup>41</sup> to assess displacement, the geometry of **3** is displaced along the pseudorotational coordinate 11.8% (12.0% with unit vectors) from the ideal trigonal bipyramidal (TBP) toward the rectangular pyramid (RP) that has O1, O5, O2, and O3 in the basal plane with the equatorial oxygen atom of the seven-membered ring, O4, as the pivotal atom in the pseudorotation process. For compounds **1** and **2**, the best fit to the pseudorotation coordinate is obtained when the equatorial oxygen atom of the six-membered phosphorinane ring (O2 for **1** and O3 for **2**) is the pivotal atom. In these cases, the displacement from the TBP toward the RP averages 7.5% (6.9% with unit vectors) and 16.3% (15.4% with unit vectors) for **1** and **2**, respectively.

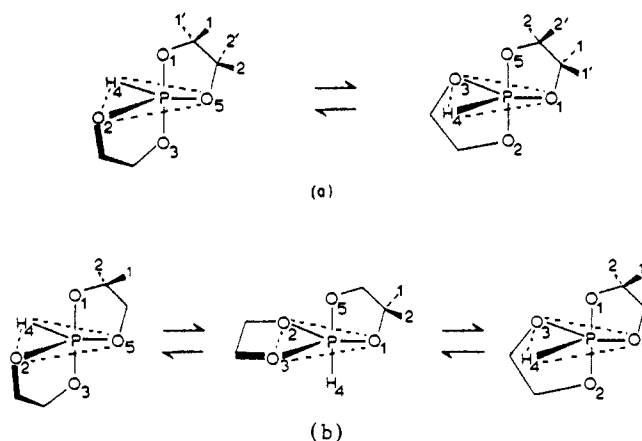
The phenylphosphorane (**4**) containing two identical phosphorinane rings is most interesting with regard to pseudorotational behavior. The molecule has crystallographic two-fold symmetry with P, C6, and C9 lying on the two-fold axis and yields a disordered structure with two half-occupied sets of positions (A and B) for the four oxygen atoms. When the A set of positions is occupied, the O2s are axial and the O1s are equatorial. When the B set of positions is occupied the O1s are axial and the O2s are equatorial. For either the A molecule or the B molecule, distortions away from the ideal TBP geometry are slight. The O–P–O and the O–P–C equatorial angles are all 120° to within the limits of the error (119.7 (3)° to 120.2 (2)°). The O–P–O axial angles are 175.2 (3)° and 174.3 (2)° for A and B, respectively, compared to the ideal value of 180°. In both cases the apical oxygen atoms are tipped toward the equatorial carbon atom C6, and the four atoms P, C6, O2A, and O2A' or P, C6, O1B, and O1B' are required by symmetry to be coplanar.

The really unique feature of **4** is found on considering the nature of the disorder that is present in the A and B molecule. Regardless of which set of oxygen positions is occupied, the six-membered rings in **4** have a boat conformation, with an apical oxygen atom and the carbon opposite it at the tips of the boat (Figure 6). Thus, when the A set of positions is occupied, carbon C1 is at the tip, and when the B set of positions is occupied, carbon C2 is at the tip. It should be emphasized that the coordinates of the nonoxygen atoms are fixed. The change in conformation comes about simply by changing the positions of the oxygen atoms.<sup>42</sup>

While the disorder appears static on the X-ray time scale, dynamic interchange between the two sets of positions for the



**Figure 8.** <sup>1</sup>H NMR spectrum of **1** in CDCl<sub>3</sub> at 20 °C. Proton signals from the methyl groups of the phosphorinane ring appear at 1.07 and 1.24 ppm and from the methyl groups of the xylyloxy group at 2.32 ppm. Multiplets appear at 4.00 and 4.21 ppm for the methylene protons of the phosphorinane ring and at 6.90–7.30 ppm for the aromatic protons.



**Figure 9.** (a) Low-temperature exchange process. (b) High-temperature process. Both processes are proceeding by Berry exchange.

oxygen atoms would correspond to Berry pseudorotation.<sup>38</sup> The axial O2As go into the equatorial O2Bs while the equatorial O1As go into the axial O1Bs, where the stationary C6 of the phenyl ring is the pivotal atom in the pseudorotation process. Concomitant with the interchange of the oxygen atoms, atoms C1 and C2 exchange chemical environments (from the prow of the boat to the floor of the boat and vice versa) and would thus be equivalent (as mirror images) on an appropriate time scale. In this sense, the end points of the Berry pseudorotational motion are isolated in the solid state and provides confirmation<sup>43</sup> that this is the process taking place in solution as the principal mechanism accounting for nonrigid behavior of phosphoranes. One would thus expect to observe only two types of methylene hydrogen atoms in the proton NMR spectrum if rapid Berry pseudorotation is taking place. The latter conclusion is in agreement with the analysis of the solution state NMR spectrum of **4** discussed in the next section.

**NMR and Intramolecular Ligand Exchange.** Figure 8 which displays the proton spectrum of **1** at 20 °C is typical of <sup>1</sup>H NMR spectra of the bicyclics, **1** and **2**, containing five-membered and six-membered rings. Measurement over the range ±90 °C shows little variation other than some broadening below the –70 to –80 °C region. The pattern obtained is consistent with a rapid intramolecular exchange of ring systems interchanging apical and equatorial sites by a simple Berry pseudorotational process (Figure 9a). In order to bring about equivalency of the methylene protons and methyl group protons of the phosphorinane ring, exchange via an activated intermediate having the five-membered ring placed diequatorially is required, Figure 9b.

The methylene multiplet, invariant over the temperature range of +98 to –78 °C, may be analyzed in terms of an ABX pattern

(38) Berry, R. S. *J. Chem. Phys.* **1960**, *32*, 933.

(39) Holmes, R. R. *J. Am. Chem. Soc.* **1975**, *97*, 5379.

(40) Holmes, R. R. *Acc. Chem. Res.* **1979**, *12*, 257.

(41) Holmes, R. R.; Deiters, J. A. *J. Am. Chem. Soc.* **1977**, *99*, 3318.

(42) When the two sets of positions for the oxygen atoms are simultaneously included, the molecule has a pseudomirror plane which passes through atoms P, C3, C4, C5, C6, and C9 and lies normal to the phenyl group. This pseudo mirror operation takes the A set of oxygen atoms into the B set of oxygen atoms and C1 into C2 (Figures 6).

(43) See ref 40 for a discussion of the pertinent background material.

Table VI. Comparison of Ring and Acyclic P-O Bond Lengths (Å)

compd	six-membered ring		five-membered ring		acyclic		ref
	P-O <sub>ap</sub>	P-O <sub>eq</sub>	P-O <sub>ap</sub>	P-O <sub>eq</sub>	P-O <sub>ap</sub>	P-O <sub>eq</sub>	
<b>1</b>	1.635 (2)	1.595 (2)	1.707 (2)	1.629 (2)		1.599 (2)	this work
<b>2</b>	1.634 (9)	1.587 (9)	1.713 (9)	1.628 (9)		1.598 (9)	this work
<b>4A<sup>a</sup></b>	1.681 (5)	1.618 (5)					this work
<b>4B<sup>a</sup></b>	1.682 (5)	1.624 (5)					this work
<b>8</b>	1.644 (4)	1.585 (4)			1.677 (4)	1.615 (4) av	5
<b>10</b>	1.696 (2)	1.610 (2)			1.649 (2)	1.599 (2) av	5
			seven-membered ring				
<b>3</b>	1.634 (3)	1.590 (4)	1.685 (4)	1.616 (3)		1.604 (3)	this work
<b>9</b>			1.678 (2)	1.601 (3)	1.679 (2)	1.605 (2) av	5
			eight-membered ring				
<b>11A<sup>a</sup></b>			1.65 (1)	1.60 (1)	1.66 (1)	1.64 (1) av	5
<b>11B<sup>a</sup></b>			1.68 (1)	1.61 (1)	1.66 (1)	1.61 (1) av	5

<sup>a</sup>See footnotes to Table V.

indicating the presence of two types of protons coupled to each other as well as to the phosphorus atom. This pattern is consistent with rapid apical-equatorial ring exchange occurring down to the low-temperature limit studied. Figure 9a illustrates the exchange showing that H1 becomes equivalent to H2 and H1' to H2'.

The fact that the high-temperature exchange process of Figure 9b does not appear to take place compared to support for this process for compound E<sup>18a</sup> in the Introduction may be due to the greater ring strain that would be encountered in placing the more constrained unsaturated five-membered rings of **1** or **2** in diequatorial positions.

Further support for the interpretation given for dynamic exchange in **1** and **2** is found from the variable-temperature spectral behavior of the bicyclic derivatives **3** and **4** containing only the larger six- and seven-membered rings. For both of these phosphoranes, the high-temperature proton spectrum expected for diequatorial ring placement in an activated intermediate is reached. Presumably the greater conformational flexibility associated with the larger rings lowers the barrier for this type of intramolecular ligand exchange, Figure 9b. Figure 10 shows partial <sup>1</sup>H NMR spectra for **3** which is very similar to that for **4** with respect to the characteristics of the phosphorinane ring system. Phosphorane **4** was previously studied by Denney et al.<sup>19</sup> At 30.8 °C, a single methylene proton is indicated at 3.69 ppm (split by phosphorus, <sup>3</sup>J(P-H) = 18.8 Hz), a single xylyloxy methyl signal at 2.26 ppm, and a single proton signal from the phosphorinane methyl groups at 0.66 ppm, consistent with the high-temperature exchange process occurring along with the lower energy process, Figures 9, parts b and a, respectively. As the temperature is lowered to -68 °C, the proton spectrum (Figure 10) changes over to the type seen for **1** and **2** except that two xylyloxy methyl signals appear at 1.80 and 2.56 ppm indicating the cessation of C-O bond rotation in addition to the stoppage of the high-temperature exchange process. A further feature appears for **3**, the emergence of signals increasing intensity at -68 °C, at 2.75 ppm in the xylyloxy methyl region and at 0.48 ppm and a shoulder at 0.77 ppm in the methyl region of the phosphorinane ring. These weak signals may signify the appearance of an isomeric form. The <sup>13</sup>C NMR at 20 °C confirms the analysis of the proton spectrum in showing one signal each from the xylyl methyl carbons and the phosphorinane ring methyl carbons.

Activation energies for exchange via the high-temperature process for **3** and **4** are equivalent within experimental uncertainty, 11.5 kcal/mol for **3** and 11.8 kcal/mol for **4**. Values within ±0.2 kcal/mol of each other are obtained independent of which signals are chosen for the calculation.<sup>28</sup> The implication for **3** is that C-O bond rotation is coupled to the pseudorotational process. However, this is not generally the case, at least for monocyclic oxyphosphorane.<sup>5</sup> Denney and co-workers<sup>19</sup> obtained an activation energy of 12.0 kcal/mol for an analogous compound to **4** where the phenyl group is replaced by methyl. The similar activation energies for diequatorial ring placement obtained for **3** and **4** may imply a greater ring strain encountered for the seven-membered ring in **3** compared to that for the six-membered ring in **4** since

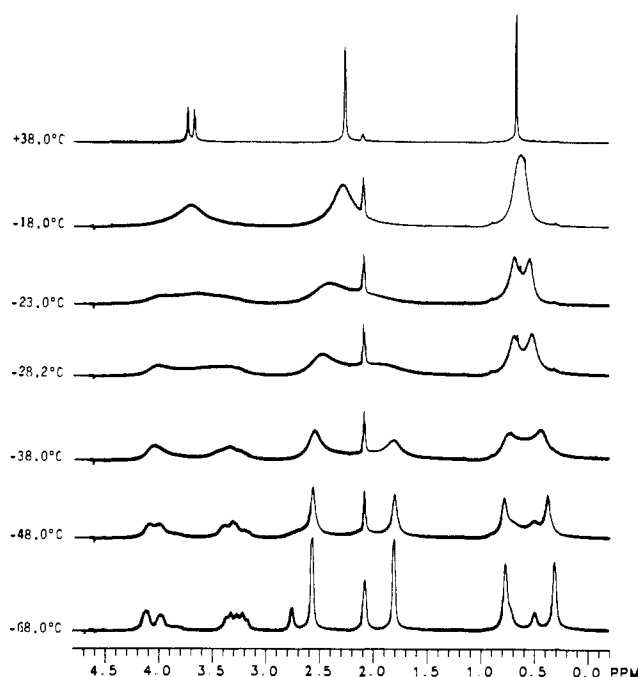
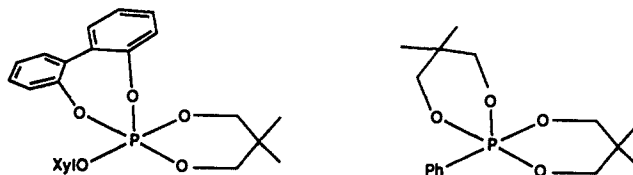


Figure 10. Partial <sup>1</sup>H NMR spectra of **3** as a function of temperature. Additional signals of possibly another isomer appear at 0.48, 0.77, and 2.75 ppm (-68 °C). The peak at 2.1 ppm is due to toluene-*d*<sub>8</sub>.

a xylyloxy group should have a greater apicophilicity relative to a phenyl group, i.e., if no unusual steric effects are encountered by placing the xylyloxy group apical. The relative destabilization of the seven-membered ring implied by the similarity in activation energies may be reasonable if one considers that the barrier states for these processes are likely square pyramids of the type encountered as the ground-state trigonal bipyramids exchange via



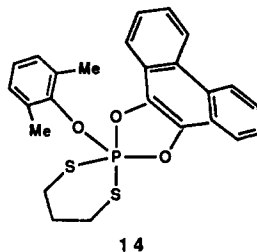
the trigonal bipyramidal intermediates having diequatorial ring conformations (Figure 9b). The considerable degree of unsaturation present in the seven-membered ring in **3** in this square-pyramidal form may provide a sufficient amount of destabilization compared to the more flexible saturated six-membered ring system in **4** to bring about the equivalence in their exchange energies. This point is discussed more fully in the accompanying paper.<sup>5</sup> However, further examples of this type of exchange process with sufficient variations are needed to provide a more definitive answer.<sup>44</sup>



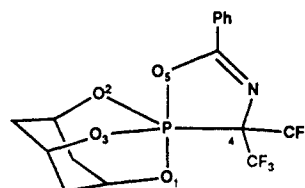
The NMR data are consistent with the retention of the solid state structures in solution undergoing simple Berry pseudorotation in all cases and, for **3** and **4**, undergoing the higher energy process as well leading to diequatorial ring placement. Accompanying these dynamic processes, conformational changes of the rings themselves must occur. The interpretation of disorder in the solid-state structure of **4** indicating the "end-points" in the simple Berry process involving apical-equatorial ring interchanges seems justifiable in view of the presence of this process in **1-4** extending over the full temperature range under investigation. Although not verified by this work, one may presuppose that the boat conformation of the six-membered rings will reorient to a chair conformation as a square-pyramidal transition state is traversed on going from one trigonal bipyramid to another either by way of the low- or high-temperature process (Figure 9). In the low-energy process, the rings will assume cis basal positions in the postulated square-pyramidal transition state and one cis basal and one axial-basal set of positions in the square pyramids for the high-energy process, as already discussed above.

In conclusion, the strong preference shown by saturated six-membered rings to assume apical-equatorial positions of a trigonal bipyramid in a boat conformation in preference to location at diequatorial sites may relate to the special stability of the boat conformation in maximizing equatorial phosphorus-oxygen bonding as originally advanced by Trippett.<sup>18a</sup> The present work is in agreement with the conclusion advanced in a structural study of the bicyclic thiophosphorane **14**,<sup>1b</sup> that a boat conformation

positioned apically-equatorially in a trigonal bipyramid is the generally preferred conformation for saturated six-membered rings in oxyphosphoranes devoid of perturbing influences or special constraints. It is also in agreement with the results of solution NMR studies<sup>17</sup> on conformational preferences of phosphorinane rings discussed in the Introduction. An example of a phosphorane containing a six-membered ring component in diequatorial positions is found in the adamantyl derivative, **15**.<sup>45</sup>



14



15

**Acknowledgment.** The support of this research by the National Science Foundation (Grant CHE88-19152) and the Army Research Office is gratefully acknowledged.

**Supplementary Material Available:** Tables of thermal parameters, additional bond lengths and angles, hydrogen atom parameters (Tables S1-S3 for **1**, Tables S4-S6 for **2**, Tables S7-S9 for **3**, and Tables S10-S12 for **4**), and atomic coordinates (Tables S13-S16 for **1-4**, respectively) (29 pages). Ordering information is given on any current masthead page.

(44) It should be noted that the six-membered rings in **1-3** are expected to undergo exchange via diequatorial ring placement similar to that indicated in **4**. However, detection of this exchange process did not occur primarily because the other ring component provided no differentiating NMR signal due to their symmetrical and/or planar structures.

(45) Carrell, H. L.; Berman, H. M.; Ricci, J. S., Jr.; Hamilton, W. C.; Ramirez, F.; Maracek, J. F.; Kramer, L.; Ugi, I. *J. Am. Chem. Soc.* **1975**, *97*, 38.